

**LED**



**IP66**

**-20°C**

**+50°C**



Spotlight

Floodlight

Ex Code: Ex de IIC T6  
Standard: GB3836.1, GB3836.2, GB3836.3  
IEC60079-1:2007,MOD  
IEC60079-7:2006,MOD



**Tripod**

### Drawing of dimension (Dimensions in mm)

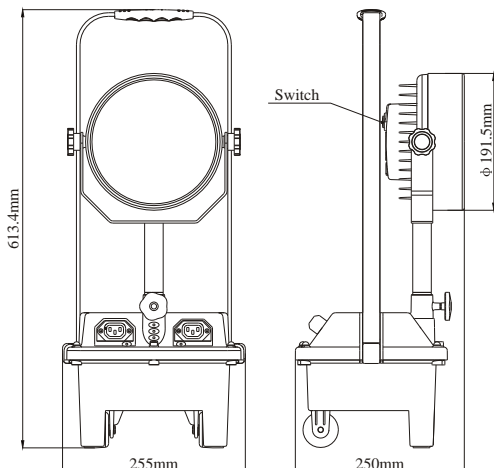

### Application

This product is widely used as mobile lighting for all kinds of night work tasks, repairing, inspection and accident relief etc.

### Characteristics of performance

- Spot light beam or Flood light beam is available according to the application.
- Safe and reliable: flame proof type of protection. Suitable to be used in various flammable and explosive environment.
- Efficient&Energy-saving: It adopts CREE LED light source, high intensity, and 100,000 hours service life. It has battery level indication function. Operator can check the energy left at any time.
- Waterproof & Durability: The housing is made of aluminium alloy, insure the unit enable to stand the strong impact. It is sealed to IP66 preventing the ingress of dust and water. Suitable to be used in all kinds of harsh environment.
- Flexible & Convenient : The lamp head has 360° rotation and 135° tilt.
- The extendable pole is optional, with 1.2 to 1.7 meters extenable height. The wheels on the bottom make the transportation more easy.
- Intelligent charging : The charger is controlled by the chip . It protect against over-charging, over discharge and short circuit. When battery is fully charged. It will switch to trickle charging automatically.

### Main specification

Specification	Unit	BW3210	
Rated Voltage	V	DC24	
Rated Capacity	Ah	12	
LED	working Voltage	V	18.5
	Rated Power	W	30 / 15
	Light Output (high/low)	lm	2,300 / 1,600
	Average Service Life	h	100,000
Continuous Runtime	High	h	12
	Low	h	24
Recharge Time	h	12	
Effective Beam Distance	m	800	
Service Life Of Battery	Recycled	≈1,000	
Dimension	L×W×H	mm	255×250×610
Net Weight	Kg	14	



**Charging socket**



**Charger**